

THE SPECIALISED BELT CONVEYORS

A PAPER PREPARED BY:

J R MCTURK / N BIRDSEY

SEPTEMBER 1991

THE SPECIALISED BELT CONVEYORS

1. SYNOPSIS

The development of belt conveyors has been an amazingly successful effort to overcome, what were considered the main limitations at that period of time.

In the past twenty years the most significant developments have been in two main areas:

- horizontal curves
- steep lifts

This paper considers the development of specialised belt conveyors and purposely ignores the significant developments to curved overland conveyors, and developments prior to about 1971.

HISTORY

The conventional troughed belt conveyor has been with us for well over one hundred years. The first conveyors were made from solid woven cotton belting, the high price of rubber at that time preventing the use of a rubber coating.

Robbins in 1885 first created the troughed roller set and numerous installations are recorded in the period prior to the first world war.

Some of the most noteworthy early events:

- 1795 First recognisable patent
- 1865 First belt conveyor in the United Kingdom
- 1885 Robbins developed the troughed roller set
- 1905 Mavor and Coulson and others first underground conveyors in the United Kingdom

The disadvantages of conventional troughed belts became more obvious in the 1950's, as cotton duck fabric was still the only longitudinal tension carrying carcass material available. Cotton duck limited the maximum tensions and resulted in stiff belt construction.

The requirements for higher longitudinal tension promoted the development of the Cable Belt system in the 1950's to overcome the tension limitations of cotton duck. This system provided separate external tensioning cables, allowing much higher tensions and also allowing large radius bends on overland conveyors.

The limitations of cotton duck also prompted the development of synthetic fabric reinforcement and also internal steel reinforcement, both of these can now provide the required longitudinal tension capabilities. Cotton duck is no longer in use now but as recently as 1964 most belt manufacturers offered only cotton duck carcass. By the early 1970's however synthetic fabric reinforcement was in widespread use.

The limitations of belt conveyors are progressively being reduced. In the last twenty years efforts have been intensified to remove the present limitations.

LIMITATIONS OF CONVENTIONAL BELT CONVEYORS

The major limitations of conventional belt conveyors are usually considered to be:

1. Low angle of lift. The angle varies depending on the angle of repose of the material being conveyed. Usually about 20° less than the angle of repose, typically this means 16 - 20° angle of lift.
2. The difficulty to negotiate tight curves. Traditional troughed belts have a limitation on horizontal radii capabilities. At best seldom below 500 m radius for fabric construction and about 1500 m radius for steel cord reinforcement on horizontal radii.
3. The difficulty to economically protect the conveyed product from the environment and visa versa.

The first two limitations:

- low angle of lift
- difficulty to negotiate tight curves,

have received the most attention, particularly in the last 20 years. The impact to and from the environment becoming increasingly important only in the last 10 years, largely because of the cost of labour. In many cases the separation of material and the environment almost happening by accident due to the solving of other limitation.

HIGH ANGLE OF LIFT

This section deals with specialised belt conveyor design that allows steep angles of lift as the main design motivation.

THE CLEATED BELT

The earliest specialised belting to allow steeper angles of lift was a cleated belt. Flexible cleats attached, or moulded as part of the top cover, provided a means of lifting the material up steeper angles.

ADVANTAGES

- Increased angle of lift depending on height of cleat.

DISADVANTAGES

- Limitations on angle of lift.
- Difficult to clean sticky material.
- No special curved capability.
- No environmental protection.
- Does not accept a belt scraper type of cleaner.
- Belt is special design.

CLEATED BELT

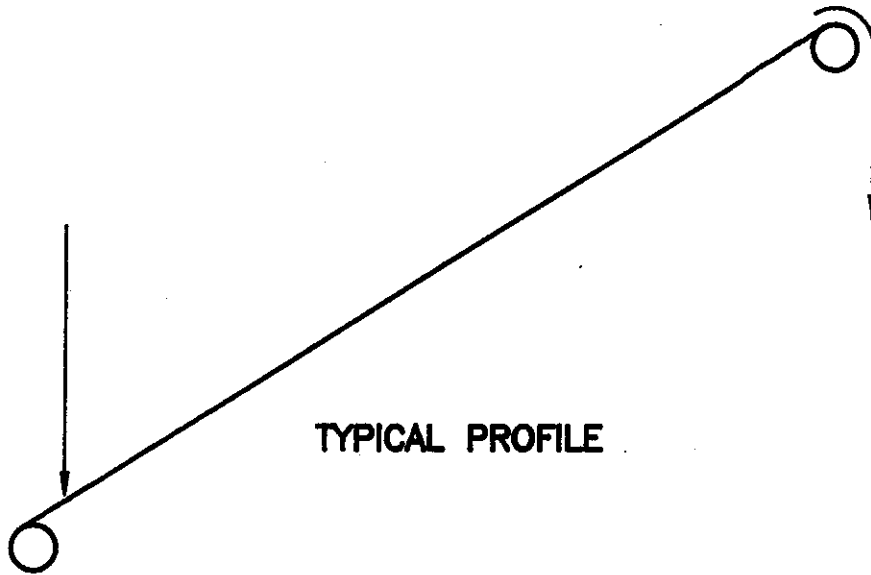

TYPICAL PROFILE

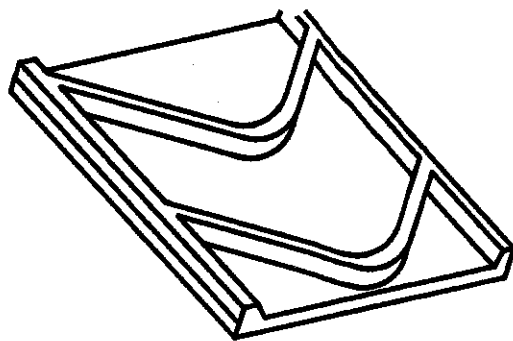

TYPICAL BELT CROSS SECTION

GENERAL

Particularly useful as a retrofit for an existing conveyor where angle of lift is at, or just beyond the limit of the material being conveyed. Many installations in RSA.

THE POCKET BELT

A development of the cleated belt, by providing a corrugated side wall in addition to the cleats used in the cleated belt. This type of belt was in widespread use in the 1970's following its introduction in 1964. The cleats combined with the sidewalls allow steep, even vertical transport.

ADVANTAGES

- Steep angles with a capability of vertical lifts.

DISADVANTAGES

- Difficult to clean sticky material.
- No special curved capability.
- Large lumps can limit service life.
- Does not accept a belt scraper type cleaner.
- The belt is a special design.
- Take-up design has limitations.
- Drive pulley cannot have more than 180° wrap (no snub).

GENERAL

A good solution for steep inclines where the material will discharge easily. Many installations in RSA.

POCKET BELT

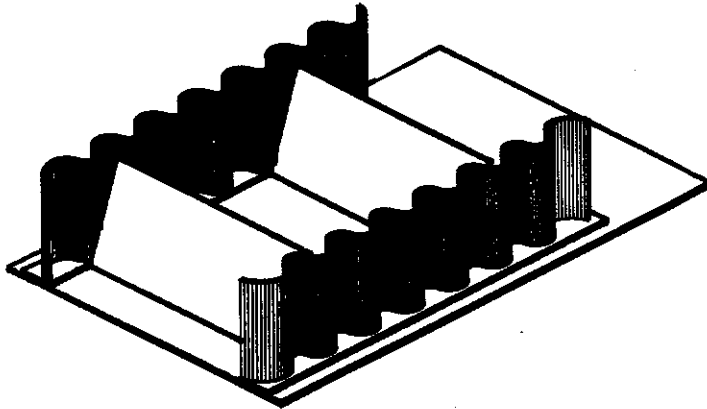

TYPICAL BELT

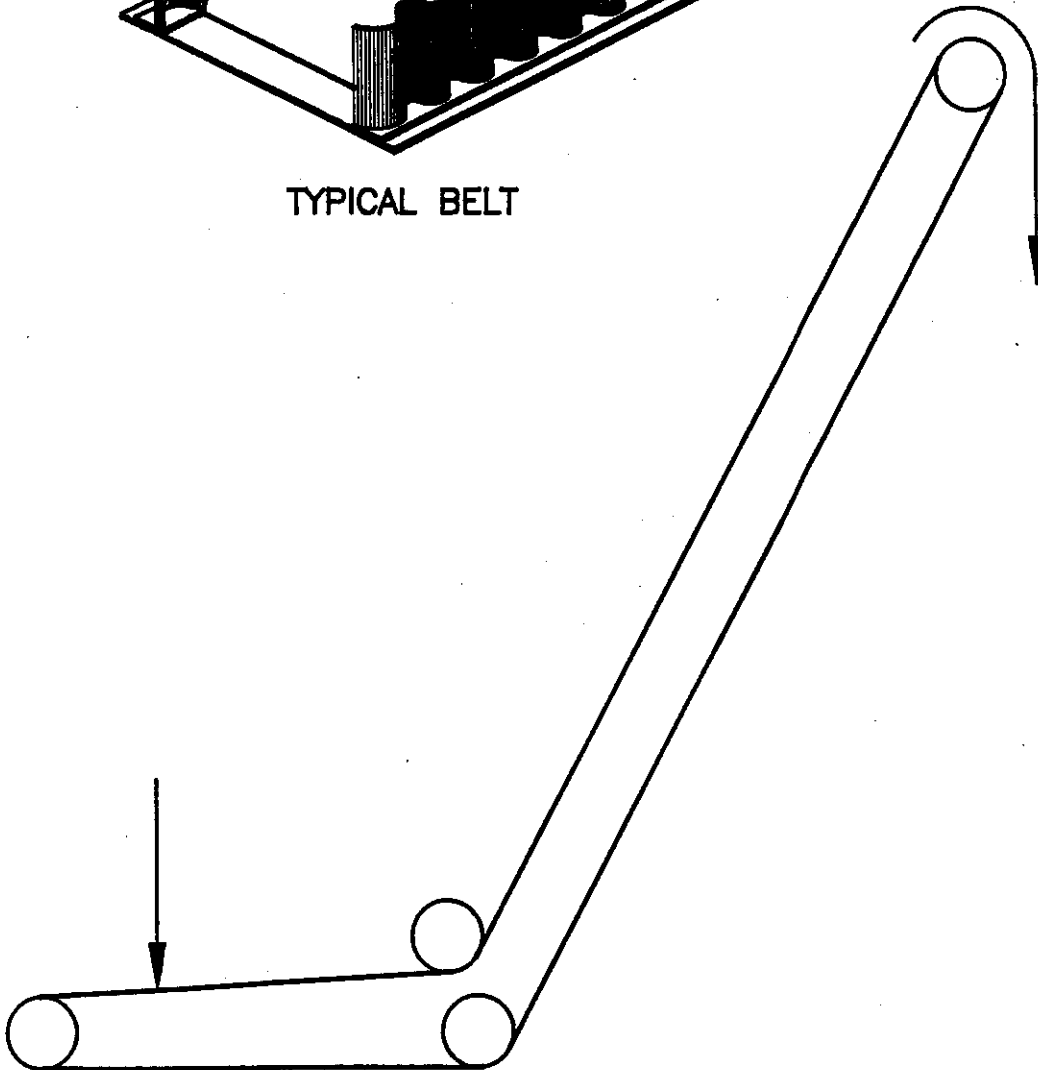

TYPICAL PROFILE

BELT AND METAL CLEATS

A recent development that consists of a steep inclined troughed belt conveyor, the material on the steep inclined troughed belt is prevented from falling downhill by scoop type metal cleats shaped to the troughed belt. These cleats are attached to a chain conveyor mounted above the troughed conveyor.

The design was patented in 1988 to overcome some of the problems experienced with Cleated and Pocket belts.

ADVANTAGES

- The plain lower carry belt uses standard belting.
- The cleats return above the carry belt preventing return belt spillage from the cleats.
- Construction is able to handle large lumps of hard rock.
- The standard belt is easy to clean.
- Easy to install intermediate drives.

DISADVANTAGES

- No vertical lifts.
- No curved capability.
- Chain used for drive.

BELT AND METAL CLEATS

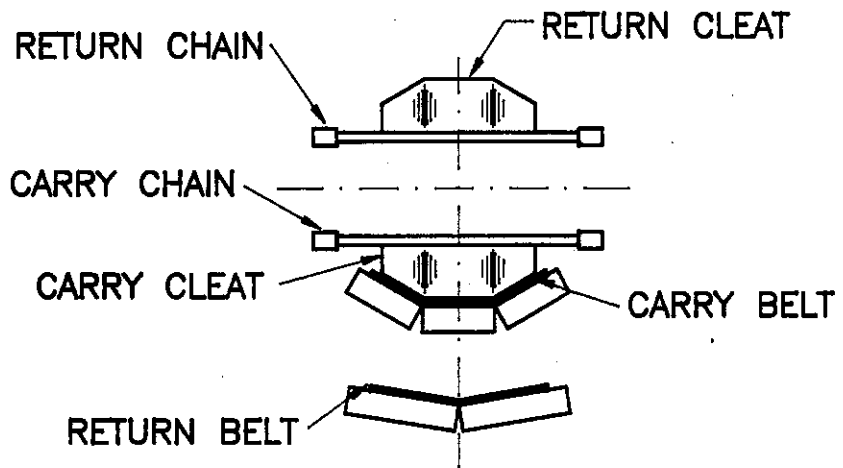
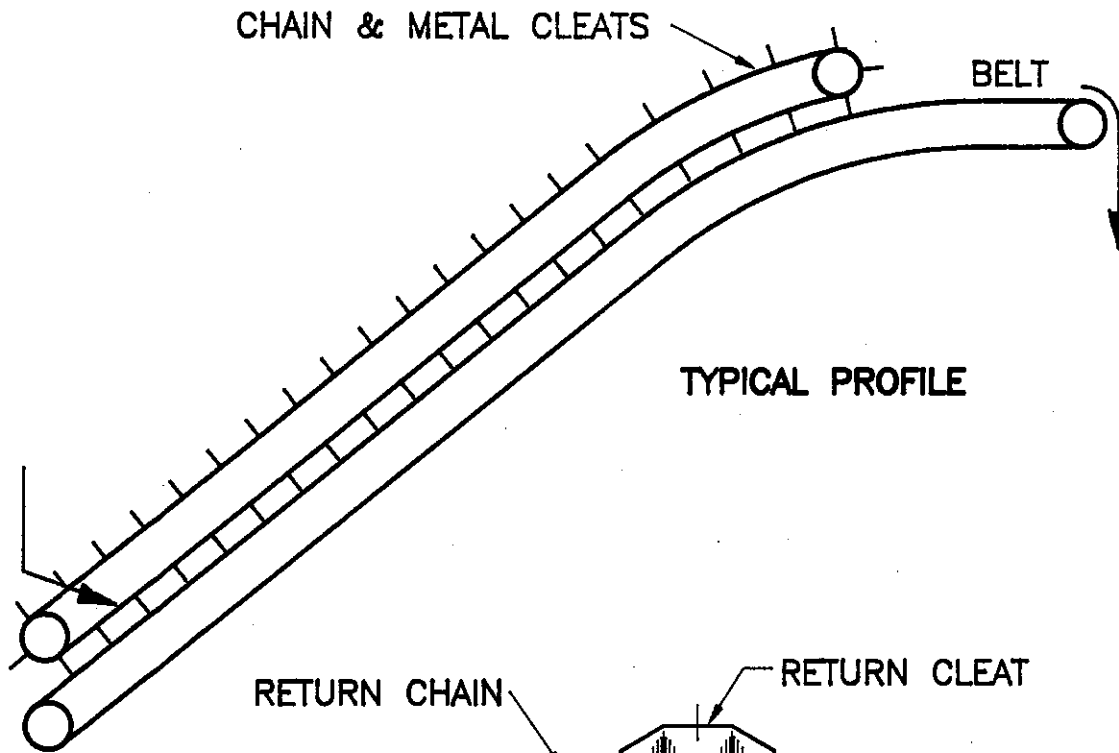

SANDWICH BELT

The development of pocket belts in Germany had a parallel development of sandwich belts in North America. A sandwich belt conveyor contains the material between an upper (or cover) belt and a lower carry belt. This type of belt conveyor is becoming more popular as it uses standard components including the belt. The design depends on the top cover exerting a pressure on to the material to hold it in place preventing downward slip. This pressure usually has to be supplemented by some form of pressure rollers onto the cover belt.

ADVANTAGES

- Increased angle of lift including vertical lift.
- Uses standard belting.
- Some environmental protection.
- Good for sticky material.

DISADVANTAGES

- Difficulty to handle large lumps, dry fines or spherical material.

- No particular curved capability.

GENERAL

Particularly easy to clean flat belt. About 10 installations in RSA.

SANDWICH BELT

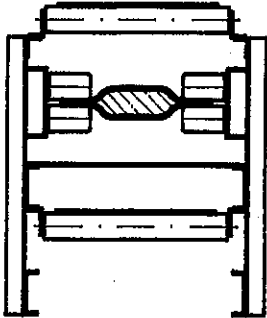

TYPICAL VERTICAL SECTION

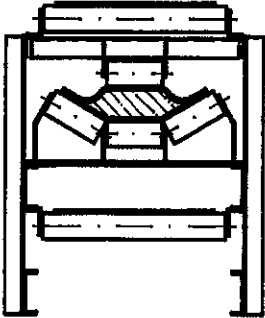

TYPICAL INCLINED SECTION

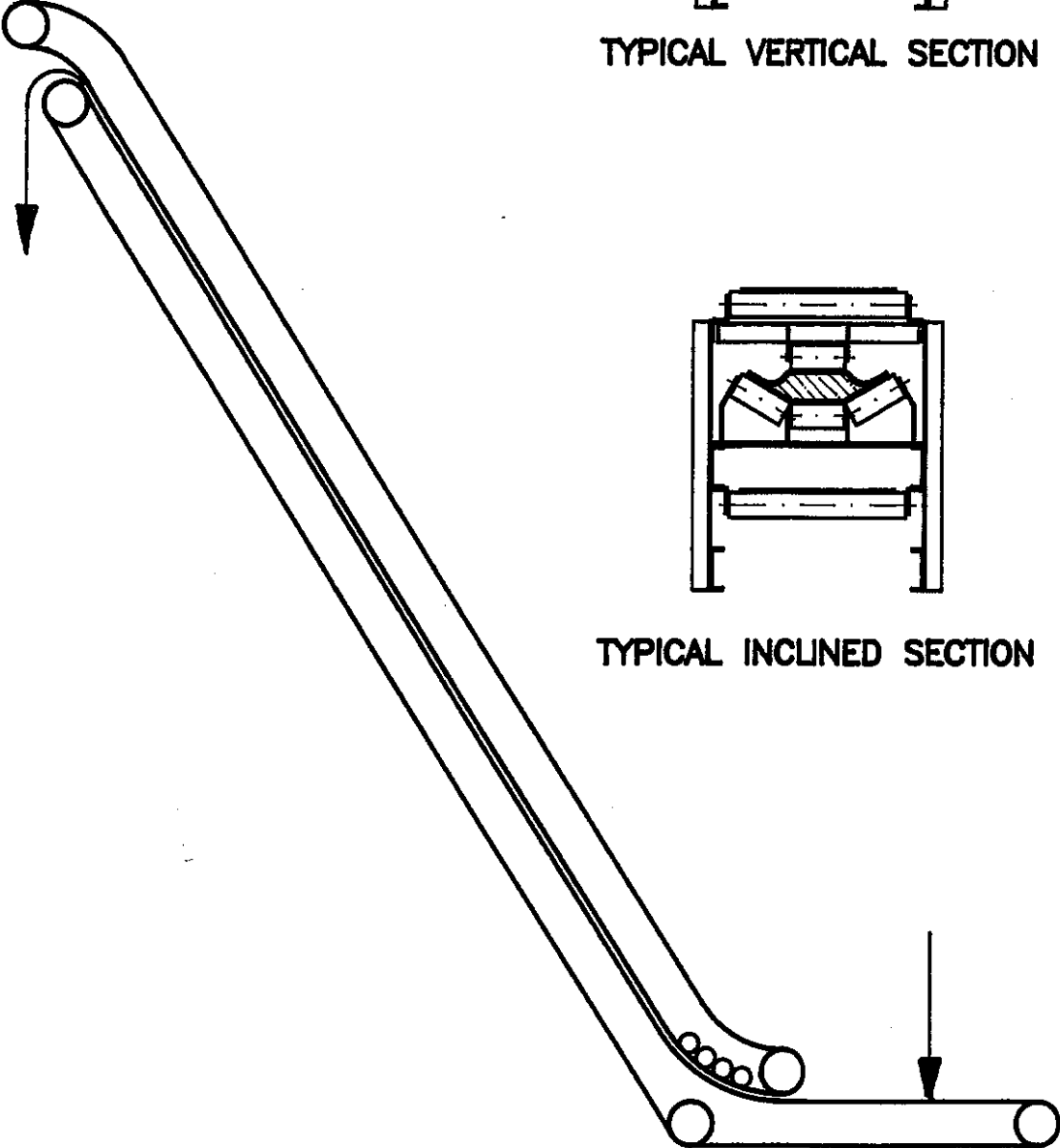

TYPICAL PROFILE

HORIZONTAL CURVED CAPABILITY

This section deals with developments that allow significant horizontal curved conveyors as opposed to the previously described conveyors that offered steep inclined capability. Some of these conveyors also have some high angle of lift ability.

HINGED BELT CONVEYOR

Essentially a fabric belt where the longitudinal tension forces are taken by fabric carcass in the central portion of the belt. This section is stiff crosswise and is flat.

On either side of the central portion is flexible areas providing a hinge zone. The hinge area has a springiness and allows the remainder of the belt to fold over the carried material and overlap above the material. The cross section is a flattened pipe shape.

The belt surrounds the material completely. By tilting the flat central portion, angling the horizontal axis up to 90°, the belt can negotiate tight horizontal radii. The edges enclosing the material provide containment and allow steeper angles of transport.

ADVANTAGES

- The belt surrounds the material.

- The belt can negotiate tight horizontal radii.
- The conveyor can transport up steeper angles say $\pm 30^\circ$.
- The return belt is closed and dirty side in.

DISADVANTAGES

- A lump size limitation.
- A very new development.
- Special belting is required.
- Longitudinal tension taken by a small portion of the belt only.
- Head, tail and take-up section can be similar to standard troughed conveyors.

GENERAL

The first commercial application was commissioned in early 1990.
No RSA installations.

HINGED BELT CONVEYOR

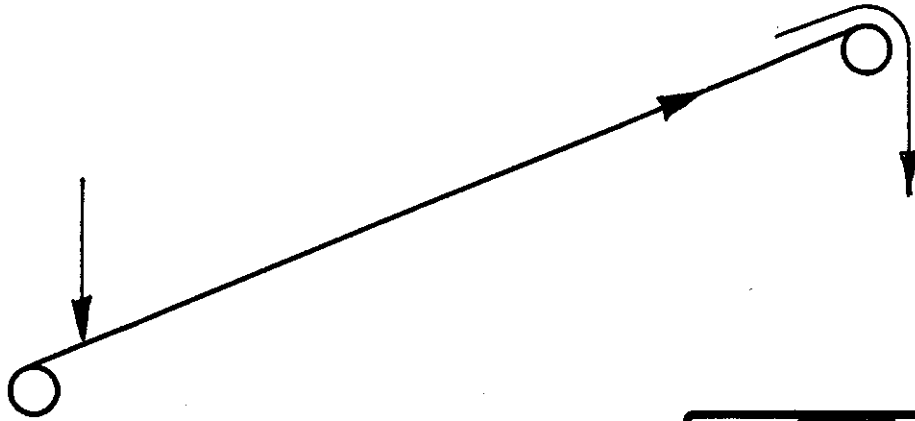

TYPICAL ELEVATION

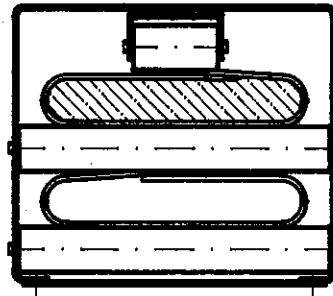

TYPICAL CROSS SECTION

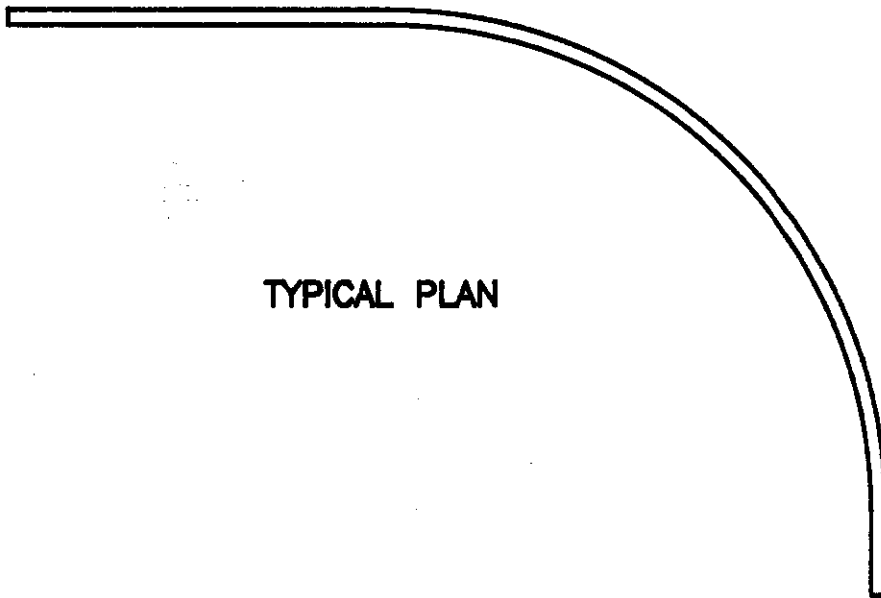

TYPICAL PLAN

THE SUSPENDED PIPE CONVEYOR

A conveyor where the belt is formed into a pipe of teardrop cross section. The two edges of the belt are enlarged to provide for the longitudinal tension forces and these edges also are used to suspend the belt. The longitudinal tension can be accommodated by steel cord or fabric reinforcement in the edges.

ADVANTAGES

- The belt surrounds the material.
- The belt can negotiate tight horizontal radii. Minimum about 1 metre.
- The conveyor can transport up steeper angles $\pm 30^\circ$.
- Easy installation of intermediate drives.
- Return belt is closed.
- Compact support structure.

DISADVANTAGES

- Specialised belting is required.
- New development.

- Limited lump size.

GENERAL

A new promising development with some commercial installations already. No commercial RSA installations.

SUSPENDED PIPE CONVEYOR

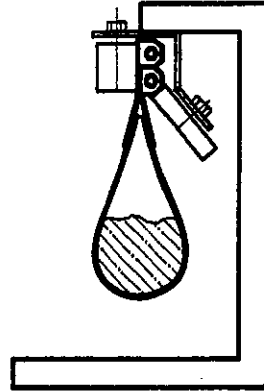

TYPICAL CROSS SECTION

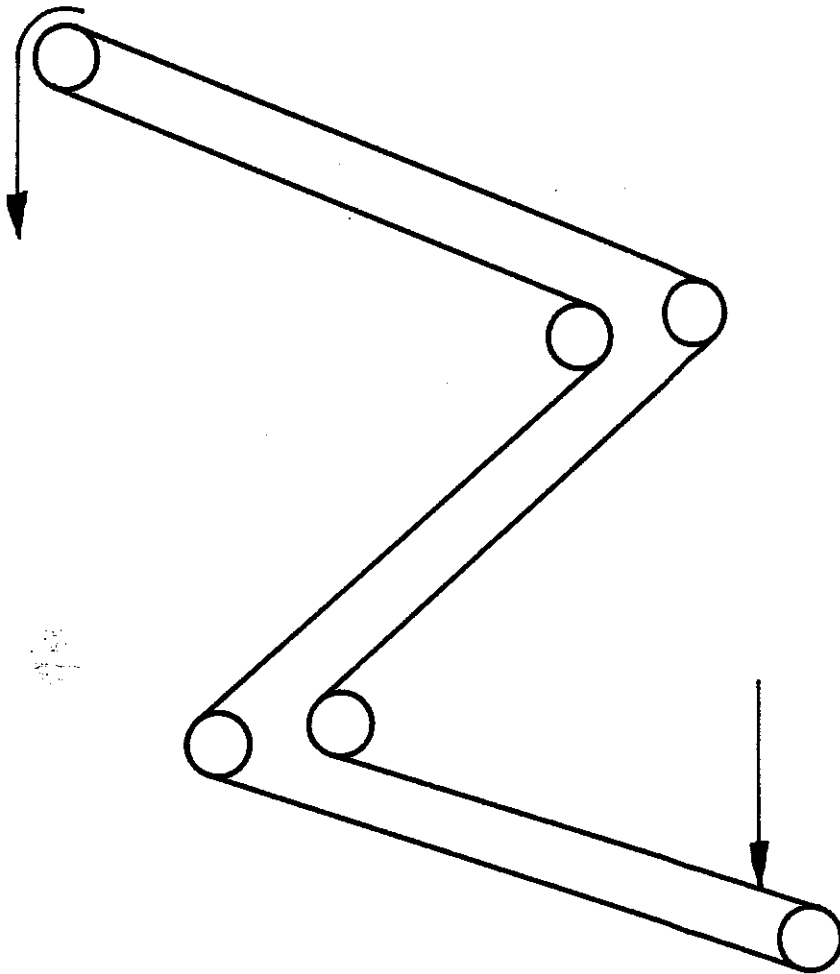

TYPICAL PROFILE

THE PIPE CONVEYOR

A belt conveyor where the carry and return belts are formed into a pipe of true circular cross section. The belt is constructed with the longitudinal tension carried by almost the full width of the belt. The section of belt near the edges has reduced cross stiffness. Return belt is turned dirty side in.

ADVANTAGES

- The belt surrounds the material.
- The conveyor can negotiate fairly tight horizontal radii. Minimum about 45 metres.
- The conveyor can transport up steeper angles +/- 30°.
- Standard pulleys, drives and take-up design.
- Established design with numerous installations.
- All components made in RSA.

DISADVANTAGES

- Specialised belting needed.

- Limited lump size capability.

GENERAL

Numerous installations in RSA.

PIPE CONVEYOR

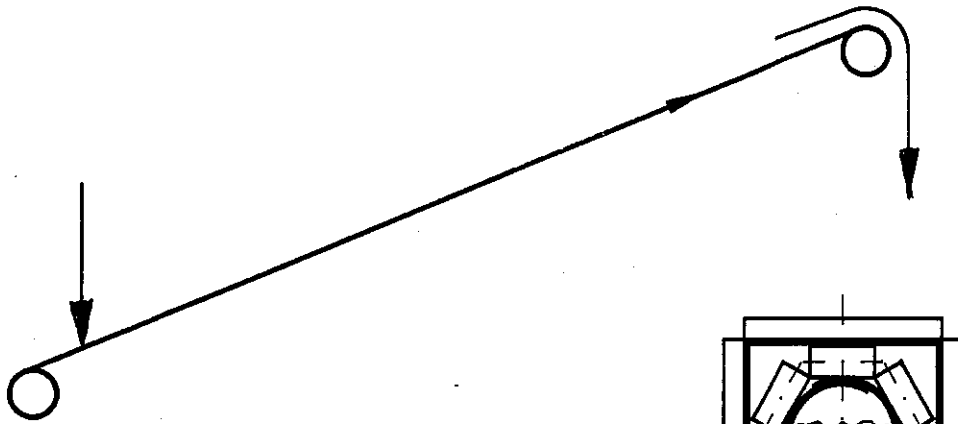

TYPICAL ELEVATION

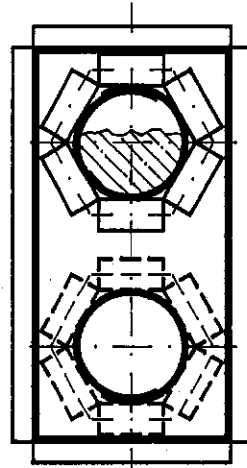

TYPICAL CROSS SECTION

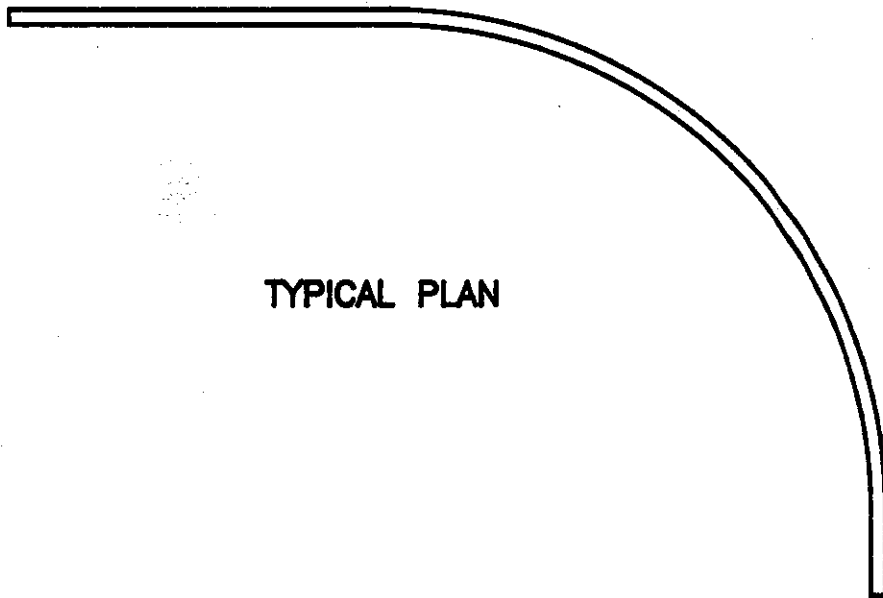

TYPICAL PLAN

FUTURE

The future developments are bound to be very exciting. It is difficult to keep up to date and this paper has only covered the developments that seem the most interesting at present. However certain requirements seem obvious and all new conveyors will tend to be judged by them.

Two main requirements at present seem to be:

1. Steep of vertical transport.
2. Ability to negotiate horizontal radii.

With the environmental considerations gradually receiving more consideration at present the developments described have only successfully overcome one of the main requirements. The market remains without a conveyor capable of overcoming all the present requirements to the satisfaction of the market place. The development of such a conveyor remains the obvious goal of all inventors and designers.